

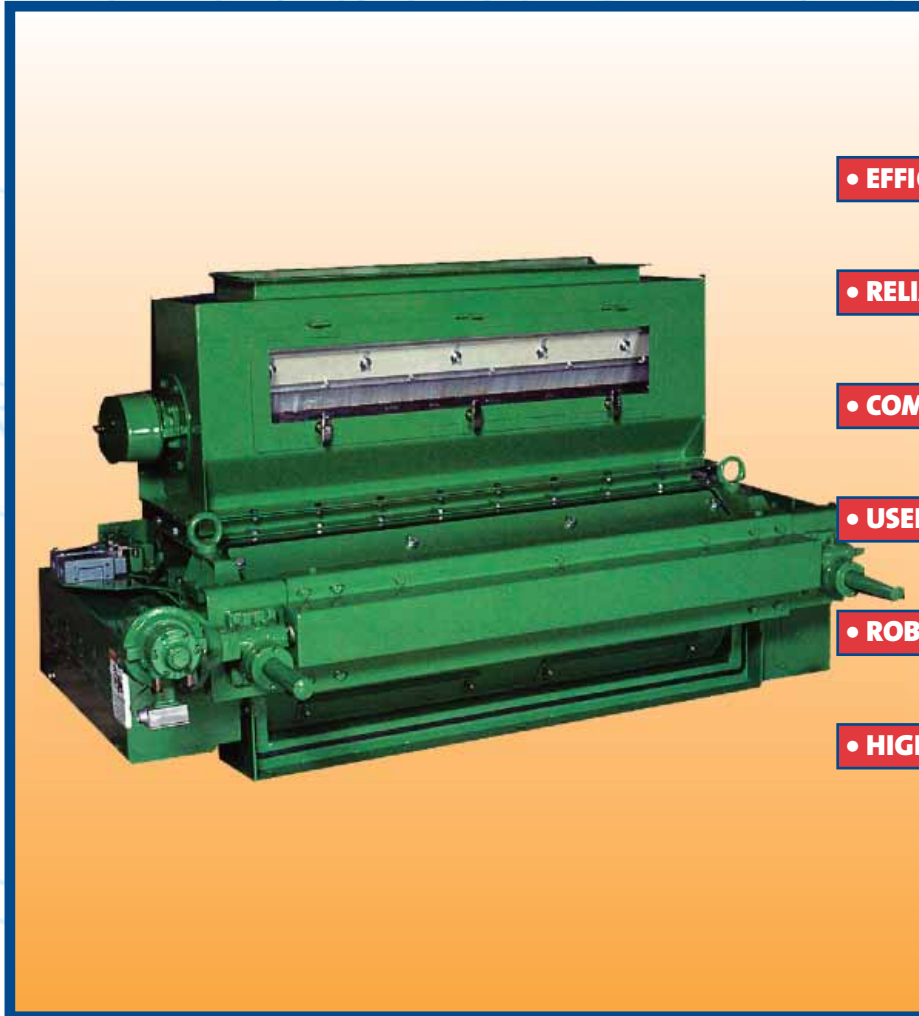

Since 1883

# Crumblers



• EFFICIENT •

• RELIABLE •

• COMPACT •

• USER-FRIENDLY •

• ROBUST •

• HIGH CAPACITY •

## *Simplicity* **THE CPM ADVANTAGE**

CPM pellet Crumblers are high-capacity, high- efficiency machines. The **heavy duty design** and user-friendly features ensure many years of continuous, reliable operation. CPM pellet crumblers are available in a variety of capacities.



Since 1883

# Your partner

As the world's largest manufacturer of pellet mills, CPM provides the best in equipment, dies, parts and services which together represent the Lowest operating cost solution to our customers.

Innovative engineering and design have been combined with the latest manufacturing technology. CPM pellet Crumblers are high-capacity (ranging from 10 to 40 t/h), high- efficiency machines. The rugged design and user-friendly features ensure many years of continuous, reliable Operation. CPM pellet crumblers are available in a variety of capacities constructed to match the output requirements of your process. Crumblers are built to operate 24 hours a day in tough running conditions.

## RELIABILITY

Extensive field research has proved the CPM Crumblers can produce continuously in the most adverse conditions worldwide. The smart no-nonsense design and CPM's high Standards ensure a long trouble-free use.

## THE FEATURES

Many proven and innovative features can be found in the CPM crumblers. Listed below are just a few.

- No bearing alignment is required.
- The discharge opening is the same size as the inlet, minimizing the size and height of the discharge hopper.
- There is a more robust bearing support system to handle roll separations forces.
- Full-length bolt-on maintenance doors provide full access to the rolls for inspection and adjustment.
- A safety grid is built into the inlet over the rolls.
- The inter-roll drive is spring-loaded and easy to adjust.
- With the full-feature roll adjust; Infinite adjustment of rolls is possible.
- Low profile for compact Installation.
- Different sizes are available to match your production capacities (uptil 40 tons per hour).

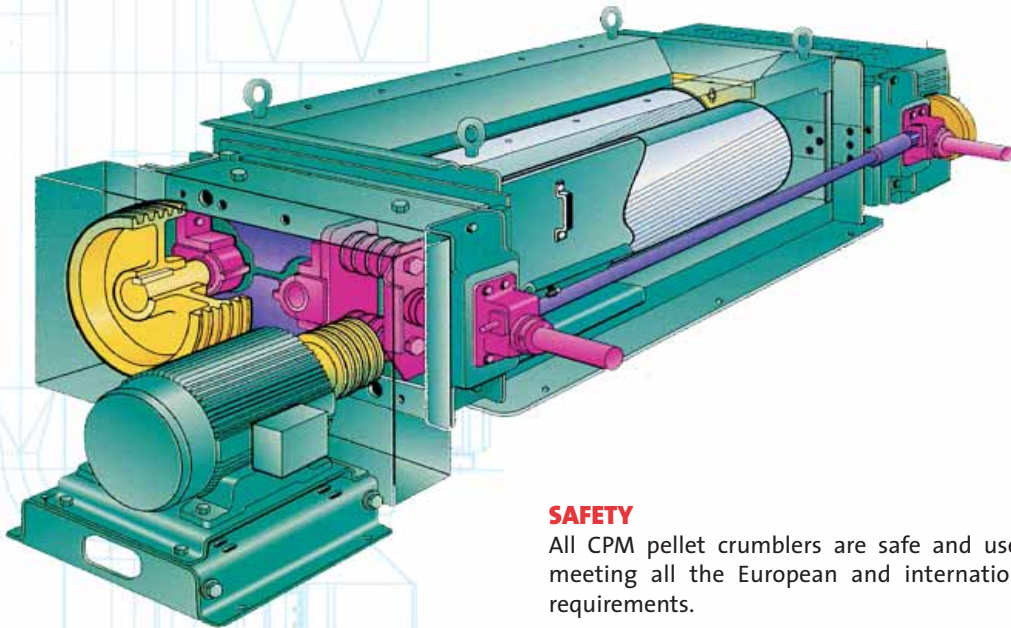

## SAFETY

All CPM pellet crumblers are safe and user-friendly, meeting all the European and international safety requirements.



855 SS (Single Stand)



855 SS with pocket feeder



1252 SS (Single Stand)



1272 SS with rollfeeder

# in productivity



- More precise roll adjustment means fewer fines.
- The inter-roll drive is belt-driven; the belt tension is spring-loaded and easy to adjust.
- Dividers with bolt-on maintenance doors are standard with double stand crumbles.
- Both sides of the rolls can be adjusted simultaneously.
- Robust bearing support system handles rolls Separation forces.
- Precision machining permits accurate adjustments of the large diameter, rigid crumbler rolls.
- Best quality, hardened, chilled iron rolls for long life.
- Rugged, durable design for continuous service and long life.
- 'Between the rolls' bypass on the model 1252 & 1272.



## OPTIONS AVAILABLE

There are many different sizes and options available to match your production capacity and meet your specific requirements.

### ROLL ADJUST

- Manual hand wheel
- Air-actuated - two position
- Full feature

### FEEDER

- Roll feeder with lever gate
- Rotary pocket feeder
- Surge panels

### GATE ACTUATOR

- Air-actuated - two position
- Air-actuated - three position
- Full feature
- Manual handwheel

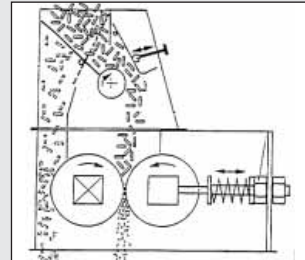
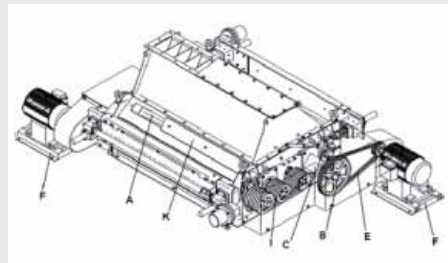

Roll Feeder 8 Serie



Roll Feeder 12 Serie

### CAPACITY RANGE (INDICATION)

- Type 855 SS (Single Stand) 10 tph
- Type 855 DS (Double Stand) 20 tph
- Type 1252 SS (Single Stand) 15 tph
- Type 1252 DS (Double Stand) 30 tph
- Type 1272 SS (Single Stand) 20 tph
- Type 1272 DS (Double Stand) 40 tph



By-pass 12 Serie

### DRIVES (1500 RPM)

- Type 855 SS (Single Stand) 11 kW
- Type 855 DS (Double Stand) 2 x 11 kW
- Type 1252 SS (Single Stand) 15 kW
- Type 1252 DS (Double Stand) 2 x 15 kW
- Type 1272 SS (Single Stand) 18 kW
- Type 1272 DS (Double Stand) 2 x 18 kW



Baffle adjustment

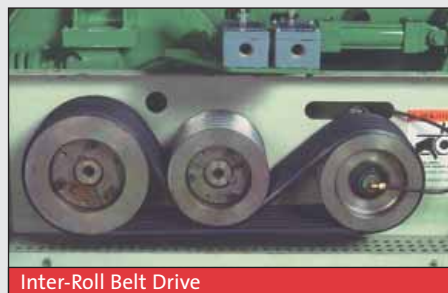

Inter-Roll Belt Drive



Roll gap adjustment



Since 1883

# Crumblers

Double Stand with feeder and divider

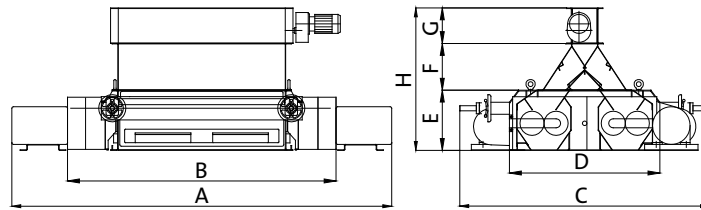

Single Stand with feeder

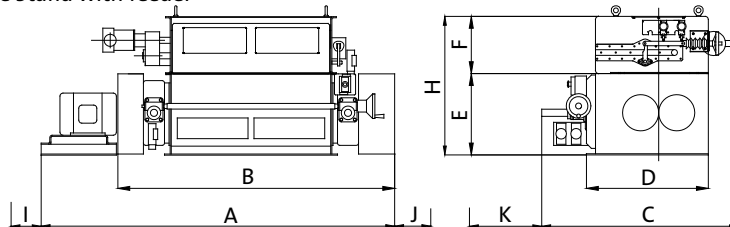

CPM crumbler dimensions

Type	A mm	B mm	C mm	D mm	E mm	F mm	G mm	H mm	K mm	Roll Diameter	Roll Length	Weight (without motor)
855 SS	1945	1728	1445	860	508	NAP	NAP	508	NAP	203 mm	1397 mm	1386 kg
855 DS	3207	2267	2108	1270	508	394	300	1202	-	2 x 203 mm	2 x 1397 mm	2545 kg
1252 SS	2985	2337	1662	1029	686	482	NAP	1168	610	305 mm	2725 mm	3946 kg
1252 DS	3024	2367	2850	2084	695	245	NAP	940	NAP	2 x 305 mm	2 x 2725 mm	6260 kg
1272 SS	3480	2845	1406	1029	687	NAP	NAP	687	610	305 mm	1829 mm	4545 kg
1272 DS	3844	2760	2259	1689	597	420	NAO	1016	610	2 x 305 mm	2 x 1829 mm	4545 kg

## WORLD-WIDE

CPM offers service through a world wide network of local agents in nearly every country. They get supported directly from the regional headquarters by teams of pelleting technology specialists.

## SALES DEPARTMENTS

Our establishments are staffed with qualified sales, engineering and service personnel and are well stocked with dies, parts and accessories. This ensures prompt efficient processing of all customer service requirements.

## CONTACT

Please feel free to contact your local agent, our offices or our Internet sites [www.cpm europe.nl](http://www.cpm europe.nl) or [www.cpmroskamp.com](http://www.cpmroskamp.com).



**CPM/Europe BV**  
 Distelweg 89  
 1031 HD Amsterdam  
 The Netherlands  
 +31 20 494 61 11 Phone  
 +31 20 636 42 94 Fax  
 info@cpmeurope.nl

**Roskamp Champion**  
 2975 Airline Circle  
 Waterloo, IA 50703 - USA  
 +1 319 232-8444 Phone  
 +1 319 236-0481 Fax  
 800 366-2563 Toll-Free  
 sales@cpmroskamp.com

**California Pellet Mill Co.**  
 1114 E. Wabash Avenue  
 Crawfordsville, IN 47933-USA  
 +1 765 362-2600 Phone  
 +1 765 362-7551 Fax  
 800 428-0846 Toll-Free  
 sales@cpmroskamp.com

**CPM/Pacific Private Ltd.**  
 21, Gul Drive  
 Singapore 629470  
 Republic of Singapore  
 +65 6 265 07 01 Phone  
 +65 6 268 64 28 Fax  
 cus.svc@cpmasia.com